

Chain and Belt Tensioner

The Elastomeric Tensioners employ a time proven design, to ensure that both chain and belt drives run under a consistent and uniform tension negating chain and belt stretch.

The Elastomeric Tensioner's benefits include:

- A one nut mounting system, which allows for 360° rotation.
- Can be pre-tensioned by up to 30°, this means that as the chain or belt stretches, the tensioner automatically takes up the slack as the elastomeric elements automatically adjust the drives tension.
- Chain and Belt life is increased by as much as 30%.
- Elastomeric parts absorb vibrations and shock loading.
- Maintenance Free – no metal on metal parts, lubrication free.
- Impervious to dust and dirt, temperature -40° to +80°
- Two holes are provided on the arm, allowing two different levels of force to be generated:
"normal" and "hard". The "hard" setting deploys approximately 25% more force.

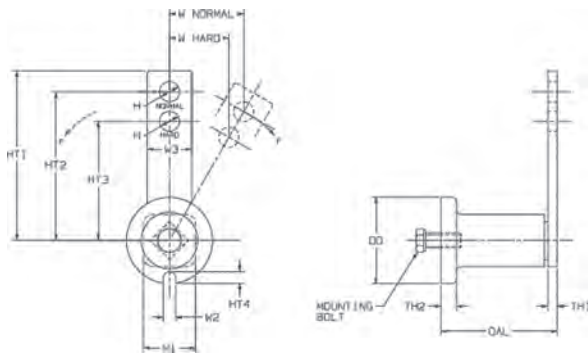
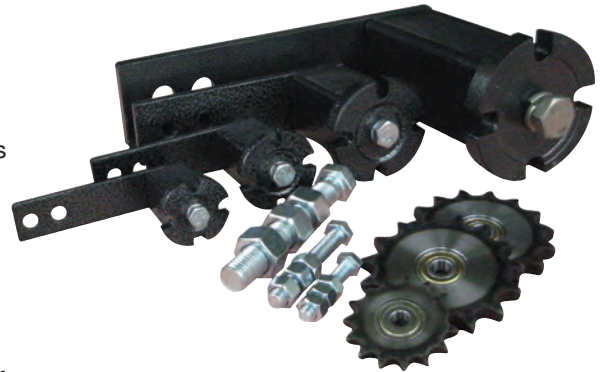

Type	OD	OAL	TH1	HT2	HT3	W3	HT1	W1	W2	TH2	HT4	H	Mounting Bolt	F in n/M 0 - 30°	Weight (kg)
SE11	35	50	5	80	60	20	90	20	7	7	6	8	M6	0-90	0.25
SE15	50	60	5	100	80	30	110	22	8	8	8	10	M8	0-140	0.45
SE18	60	75	6	100	80	40	115	35	9	10	11	10	M10	0-320	0.75
SE27	80	110	8	135	105	50	155	45	10	15	13	12	M12	0-820	1.8
SE38	105	140	10	180	140	65	200	62	13	16	15	20	M16	0-1500	3.7
SE45	115	200	12	225	190	70	260	78	17	18	20	20	M20	0-2500	6.5

Type	Angle of Pretension (Force required in psi)						Mounting Bolt Torque
	10°		20°		30°		
	Normal	Hard	Normal	Hard	Normal	Hard	
SE11	3.4	4.5	9.0	11.9	18.0	23.9	89
SE15	5.6	7.0	14.6	18.2	30.4	37.8	221
SE18	16.9	20.9	40.5	50.6	78.7	98.2	434
SE27	33.8	43.8	85.4	111.1	179.8	233.8	761
SE38	65.3	81.4	164.1	205.0	337.2	421.5	1,859
SE45	112.5	140.5	292.5	365.6	584.5	730.7	3,629

Tensioner Selection		
Chain	Belt	Tensioner
25-1	A	SE11
35-1-2-3	A, B	SE15
35-1-2-3	B, C	SE18
40-1-2-3		
40-3	D, E	SE27
50-1-2-3		
60-1-2-3		
80-1-2-3		SE38
80-3		SE45
100-1-2-3		
120-1-2-3		
140-1-2		
160-1-2		
180-1-2		
200-1-2		

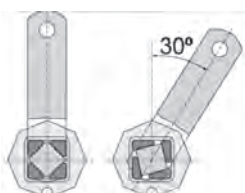

The optimum angle of pretension is 20° the maximum angle is 30°. At 20° the tensioner has maximum capability to absorb vibrations and shock loads, and still have enough arc motion to automatically take up belt or chain stretch.